



Link Controls

Stuart Road, Manor Park, Runcorn, Cheshire, WA7 1TS

T: +44 (0)1928 579050 F: +44 (0)1928 579359 www.linkcontrols.co.uk enquiries@linkcontrols.co.uk

MDF Ex d

Direct Drive | Hazardous Area Equipment

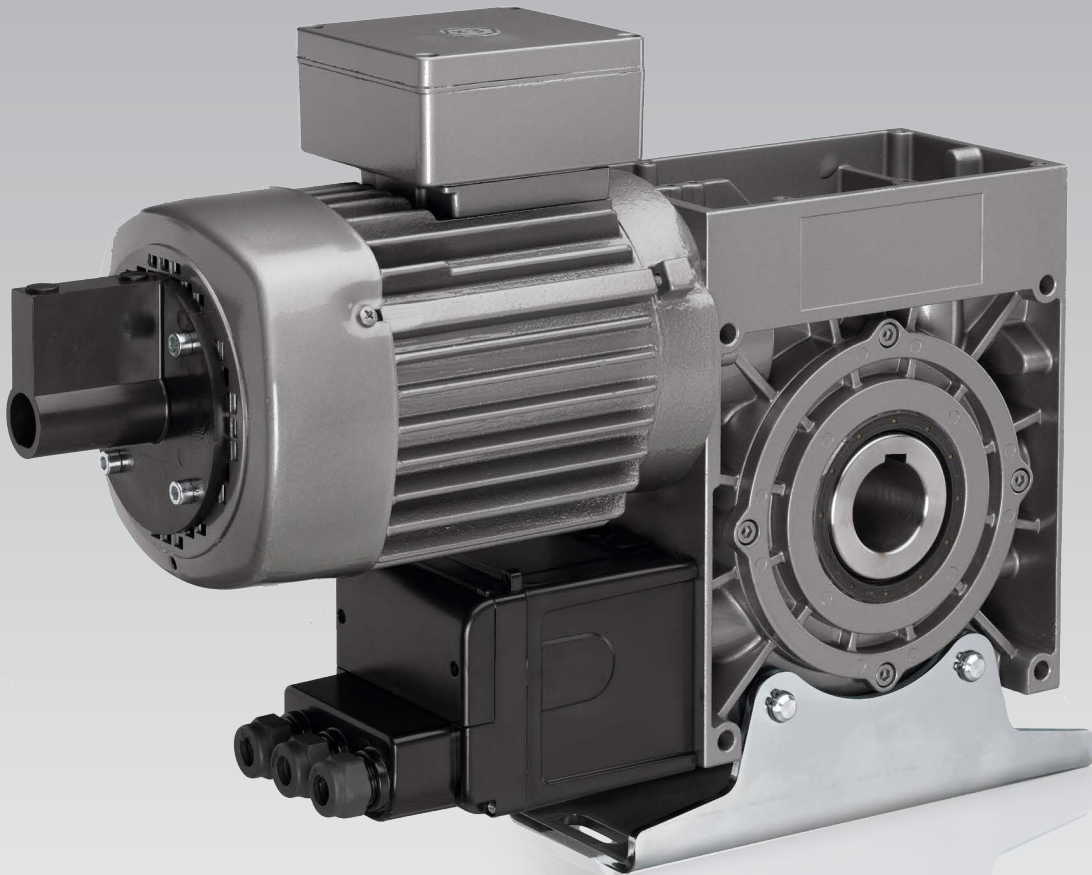

220Nm

400Nm

750Nm

3ph

IP.55

0.75kW

1.1kW

1.5kW



ZONE 1 & 2, IIB T4

Hazardous areas are places in which a dangerous explosive atmosphere exists as a result of local and operational conditions. Link Controls offer many operators and controls off the shelf and can design and build custom solutions for hazardous area applications. The MDF Ex d operators are direct drive operators that provide solutions for door automation within a hazardous area.

MDF

Ex d Range



PRODUCT DESCRIPTION

The MDF 20-22-12 slip-on drive from the MDF Exd range are specially designed for use in areas where there is a risk of explosion.

The operator is available in 0.75kW power size with 400V Three Phase Explosion Proof motor. This model uses an industrial duty motor and hence provides high starting torque. The operator comes with an ATEX rating of ZONE 1 & 2, IIB, T4 Rated Operators (Gas Only).

Stock Code: 21-4920

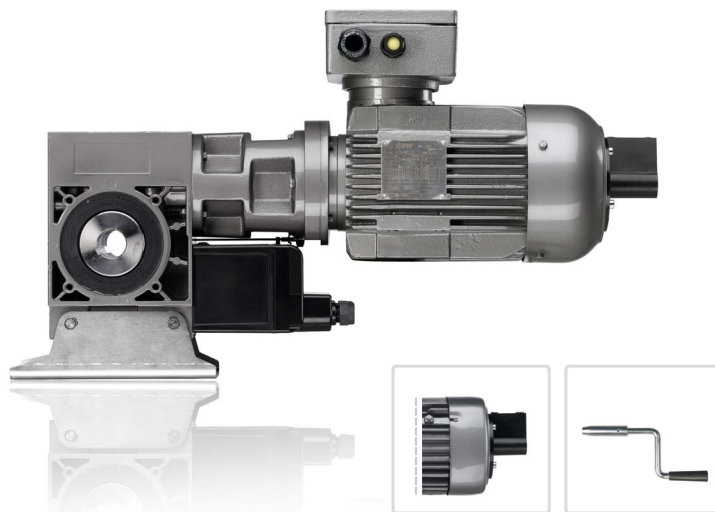

Product Features

- I.P. 55 environment protection
- High starting torque - industrial duty explosion proof motor
- Industry standard 30mm hollow bore
- IIC, T4 available on request
- Hand crank operation

Technical Information

| Technical Information | MDF20-22-12 |
|--------------------------|---------------|
| Power (kW) | 0.75 |
| Torque (Nm) | 220 |
| Output Speed (R.P.M.) | 12 |
| Environmental Protection | IP.55 |
| Current (Amps) | 2.1 |
| Power Supply | 400V/3ph/50Hz |

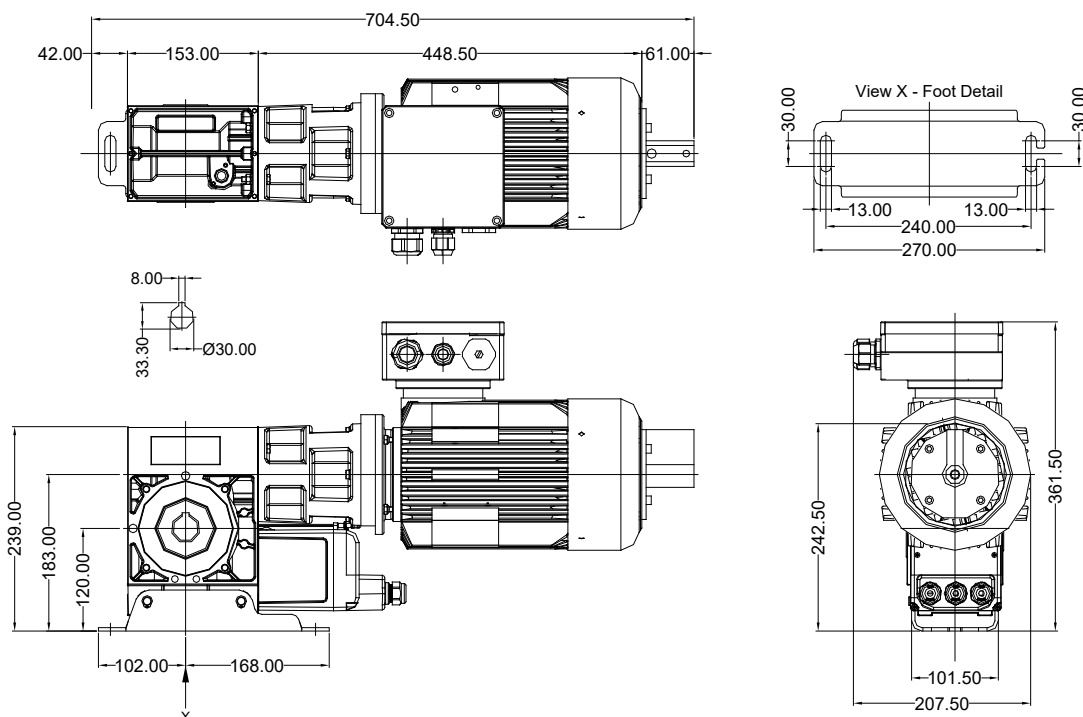

MDF 30-40-15 Ex de

Technical Datasheet

Link Controls

+44 (0)1928 579 050
enquiries@linkcontrols.co.uk
www.linkcontrols.co.uk



PRODUCT DESCRIPTION

The MDF 30-40-15 slip-on drive from the MDF Exd range are specially designed for use in areas where there is a risk of explosion.

The operator is available in 1.1kW power size with 400V Three Phase Explosion Proof motor. This model uses an industrial duty motor and hence provides high starting torque. The operator comes with an ATEX rating of ZONE 1 & 2, IIB, T4 Rated Operators (Gas Only)

Stock Code: 21-4934

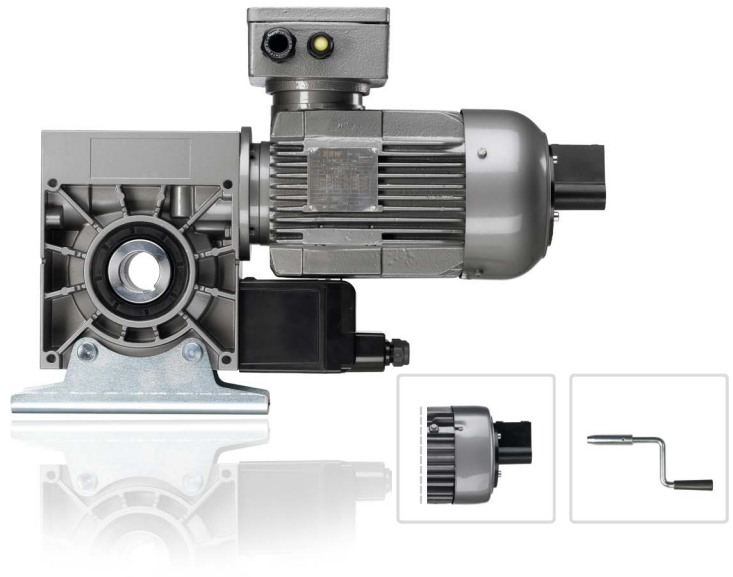

Product Features

- I.P. 55 environment protection
- High starting torque - industrial duty explosion proof motor
- Industry standard 40mm hollow bore
- IIC, T4 available on request
- Hand crank operation

Technical Information

MDF30-40-15

| | |
|--------------------------|---------------|
| Power (kW) | 1.1 |
| Torque (Nm) | 400 |
| Output Speed (R.P.M.) | 15 |
| Environmental Protection | IP55 |
| Current (Amps) | 2.4 |
| Power Supply | 400V/3ph/50Hz |

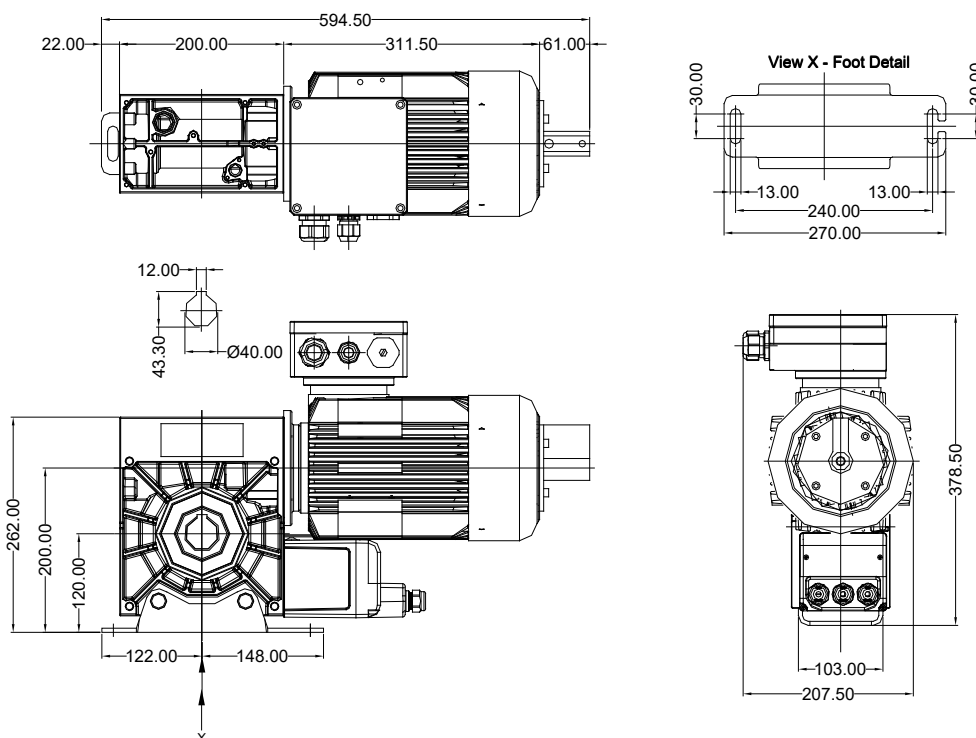

Please Contact Our Sales Department On 01928 579050 For Further Information



PRODUCT DESCRIPTION

The MDF 50-75-10 slip-on drive from the MDF Exd range are specially designed for use in areas where there is a risk of explosion.

The operator is available in 1.5kW power size with 400V Three Phase Explosion Proof motor. This model uses an industrial duty motor and hence provides high starting torque. The operator comes with an ATEX rating of ZONE 1 & 2, IIB, T4 Rated Operators (Gas Only).

Stock Code: 21-4950

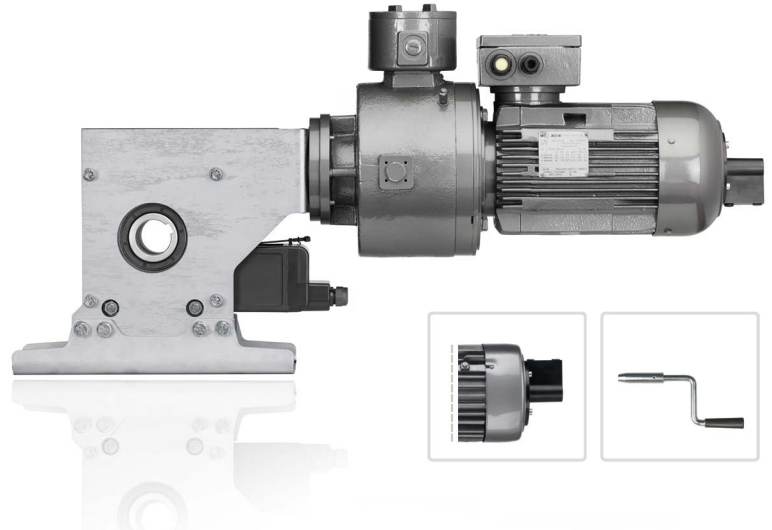

Product Features

- I.P. 55 environment protection
- High starting torque - industrial duty explosion proof motor
- Industry standard 50mm hollow bore
- IIC, T4 available on request
- Hand crank operation

Technical Information

MDF50-75-10

| | |
|--------------------------|---------------|
| Power (kW) | 1.5 |
| Torque (Nm) | 750 |
| Output Speed (R.P.M.) | 10 |
| Environmental Protection | IP.55 |
| Current (Amps) | 3.8 |
| Power Supply | 400V/3ph/50Hz |

