

BULL 464 / 624

Sliding Gate Operators | Domestic Use

Automation for Sliding Gates



BULL 464:- Up to 400kg
BULL 624:- Up to 600kg
 Full metal release system

Control with built-in encoder
 and receiver personalised
 release key

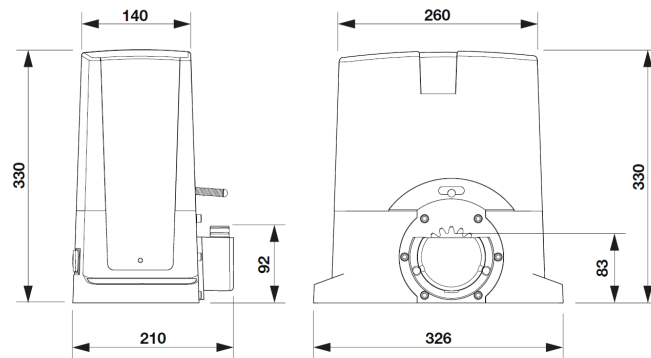

Product Features

- * 24 Vdc geared motor for intensive use, with built-in control unit, ESA SYSTEM and encoder
- * The encoder device ensures maximum safety and precision in the gate moving phases
- * Amperometric sensor obstacle detection system to prevent crushing
- * Battery back up system ready

DATA	BULL464	BULL624
Power Supply	230VAC (50-60Hz)	230VAC (50-60Hz)
Motor Supply	1ph 24VDC	1ph 24VDC
Max Absorbed Current	0.4A	0.5A
Max Thrust	428N	857N
Opening Speed	6.7-11 m/min	5.8-9.75 m/min
Operation Cycle	Intensive Use	Intensive Use
Protection Level	IP44	IP44
Operating Temp.	-20°C/+50°C	-20°C/+50°C
Max Gate Weight	450kg	600kg
Rack Required	RI.M4F / Z	RI.M4F / Z

Please Contact Our Sales Department On 01928 579050 For Further Information