

BULL 10M / 15M / 20T

Sliding Gate Operators | Commercial Use

Automation for Sliding Gates



BULL 10M:- Up to 1,000kg Control with built-in encoder
BULL 15M:- Up to 1,500kg and receiver personalised
BULL 20T:- Up to 2,000kg release key

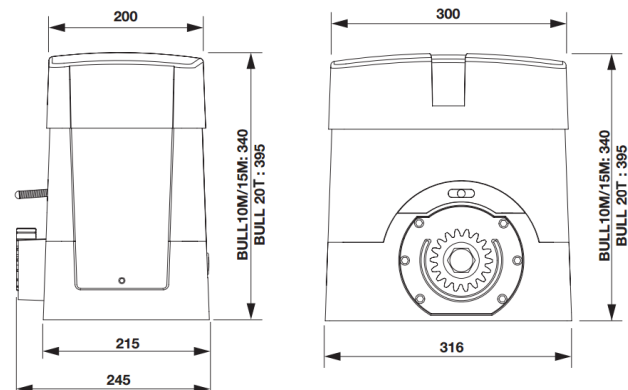

Product Features

- * 230 Vac with built-in control unit and encoder
- * 400 Vac geared motor, control unit separate (**BULL 20T**)
- * The encoder device ensures crush prevention and precision in the gate moving phases
- * Self-ventilating for increased usage intensity

DATA	BULL10M	BULL15M	BULL20T
Power Supply	230VAC (50-60Hz)	230VAC (50-60Hz)	400VAC (50-60Hz)
Motor Supply	230VAC	230VAC	400VAC
Max Absorbed Current	1.6A	2.5	1.7A
Max Thrust	1000N	1250N	2000N
Opening Speed	10.5 m/min	10.5 m/min	Intensive Use
Operation Cycle	40%	60%	40%
Protection Level	IP44	IP44	IP44
Operating Temp.	-20°C/+50°C	-20°C/+50°C	-20°C/+50°C
Max Gate Weight	1000kg	1500kg	2000kg
Rack Required	RI.M4F / Z	RI.M4F / Z	RI.M4F / M4Z / M6Z

Please Contact Our Sales Department On 01928 579050 For Further Information